

PARAMOUNT
EXPECT MORE...

Catalogue

Series P1S

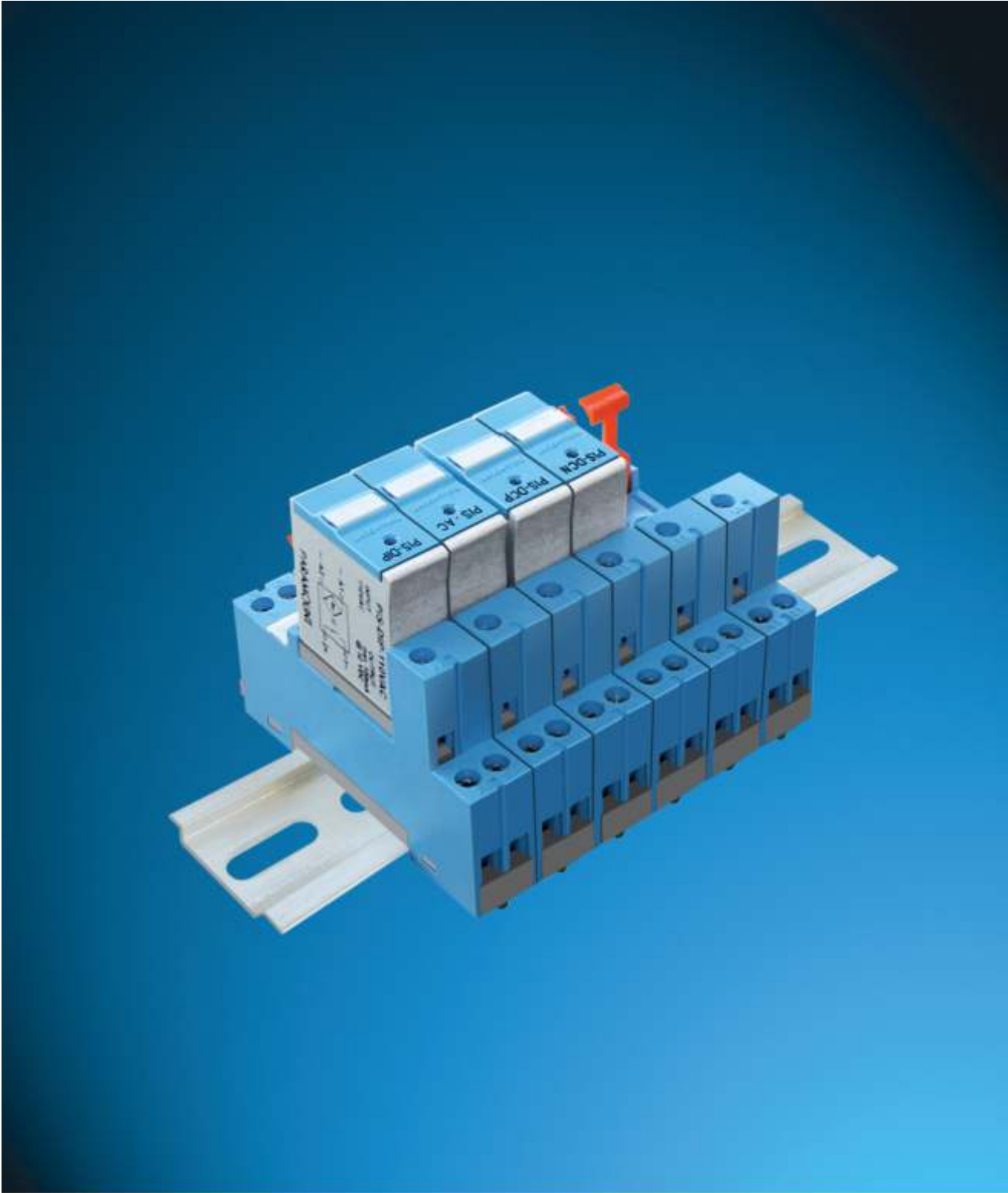

P1S - SSR

SOLID STATE RELAYS WITH DIN RAIL & PCB MOUNTABLE SOCKETS

P1S AC

For AC Industrial Loads
One Open Contact
Output : 3A @ 24-250VAC
Input : 5-32 VDC

P1S AZ

For AC Resistive Loads
One Open Contact
Output : 3A @ 24-250VAC
Input : 5-32 VDC

P1S DIP

Solid State Relay for Low Current
Input Application
DC Resistive Load
Common Positive Output
One Open Contact
Output : 100mA @ 32VDC Max
Input : 24 VDC / 110 VAC / 220 VDC
115 VAC / 230 VAC

P1S DCP

DC Inductive or Resistive Load
Common Positive Output
One Open Contact
Output : 2A @ 5-50 VDC
Input : 5-32 VDC

P1S DCN

DC Inductive or Resistive Load
Common Negative Output
One Open Contact
Output : 2A @ 5-50 VDC
Input : 5-32 VDC

P1S DIN

Solid State Relay for Low Current
Input Application
DC Resistive Load
Common Negative Output
One Open Contact
Output : 100mA @ 32VDC Max
Input : 24 VDC / 110 VAC / 220 VDC
115 VAC / 230 VAC

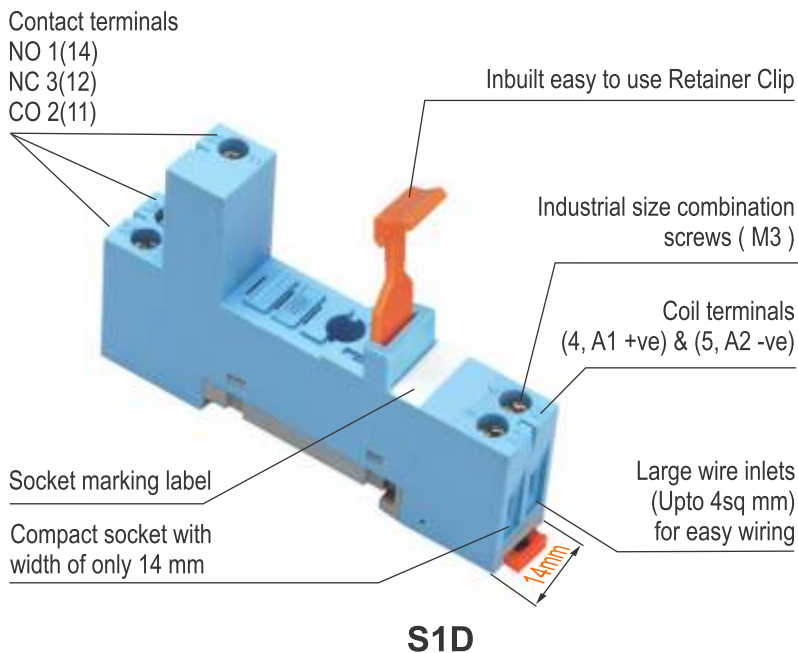
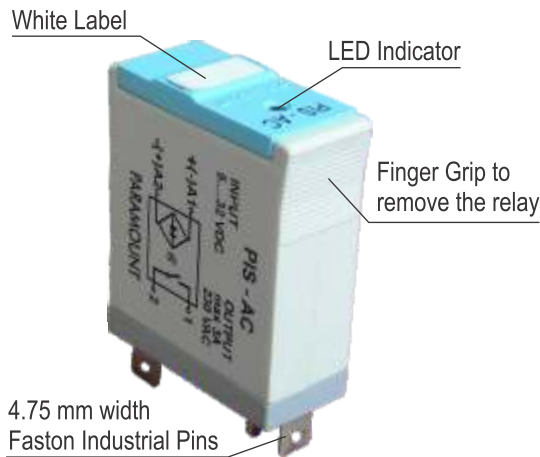

S1D

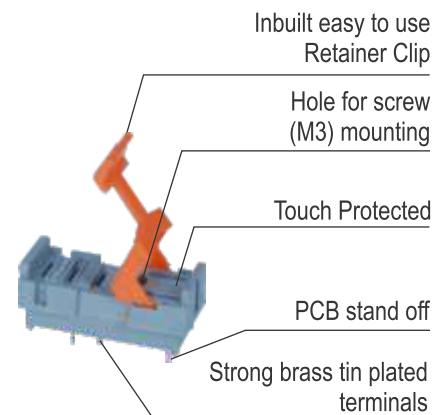

S1P



P1S-AC

Solid State Relay

AC Inductive load switching

One open contact

3A @ 24 250V AC,50/60 Hz



Input	Polarity protec
Range of input voltage	5 ...32 VDC
Drop-out voltage	< 2.5 VDC
Input current	5 ... 15 mA
Current stabilizer	Yes
Peak inrush voltage protection	EC-1000-4-5 level 1

P1S-AC AC Instantaneous output

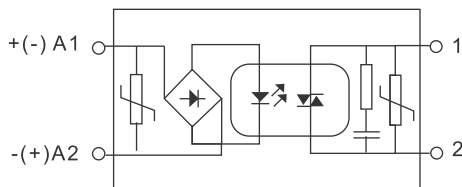

Output, Instantaneous

Max. Output current	3A
Minimum output current	50mA
Max. output voltage	250 VAC
Minimum output voltage	24 VAC
Max. drop out voltage	< 1.5 VAC
Max. leakage current at 48 Vdc	0.55 mA
Max. Dv/dt	500 V/us
I ² t for 10ms. fuse	50 A ² /s

P1S-AC Max. AC load VS. amb

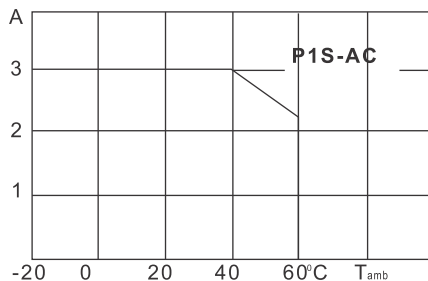

Specifications

DI-electric Strength Input / Output	4 KV / 1min.
Operate Time	1/2 cycle
Release Time	2 ms +1/2 cycle
Working Temperature max.	60°C
Storage temperature	100°C
Weight	28 gr. Max.

Application

It is specially suitable to switch inductive loads upto 3A / 250V AC In switching loads with a high inrush or over current (max.Di/dt 50us) as transformers, motors or fluorescents, the maximum output current will limit 2A.

Dimensions in mm.

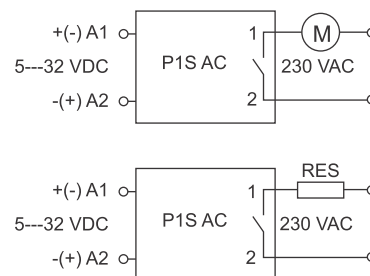
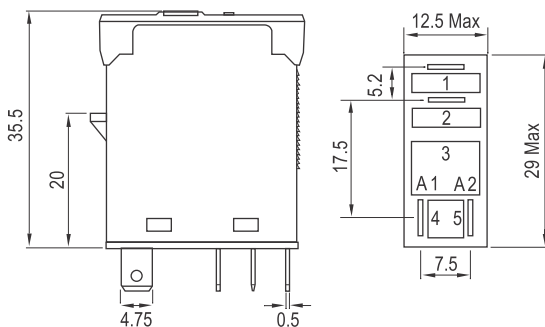

Approvals





P1S-AZ

Solid State Relay

AC resistive loads switching.

One open contact

3A @ 24 250V AC, 50/60 Hz



Input	Polarity protec
Range Of Input Voltage	532 VDC
Drop-out Voltage	< 2.5 VDC
Input Current	5 ... 15 mA
Current Stabilizer	Yes
Peak Inrush Voltage Protection	EC-1000-4-5 level 1

P1S-AZ AC synchronized to zero

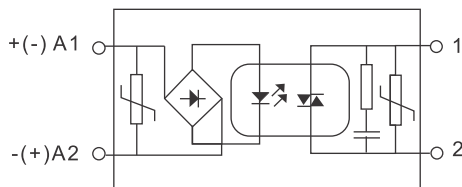

Out, Synchronized to Zero

Max. Output Current	3A
Minimum Output Current	50mA
Max. Output Voltage	250 VAC
Minimum Output Voltage	24 VAC
Max. Drop Out Voltage	< 1.5 VAC
Max. Leakage Current At 48 Vdc	0.55 mA
Max. Dv/dt	500 V/us
$I^2 t$ for 10ms. Fuse	50 A ² /s

Max. DC load vs. Ambient Temperature

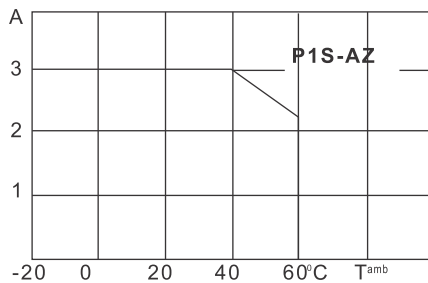

Specifications

DI-electric Strength Input / Output	4 KV / 1min.
Operate Time	1/2 cycle
Release Time	2 ms + 1/2 cycle
Working Temperature max.	60°C
Storage temperature	100°C
Weight	28 gr. Max.

Application

It switches AC resistive loads up to 3A / 250V AC in the zero point of the tension and avoids any over current peak in the connection. Suitable to switch resistors, incandescent lamp, signaling etc. Not suitable for inductive loads

Not suitable for Inductive loads

Dimensions in mm.

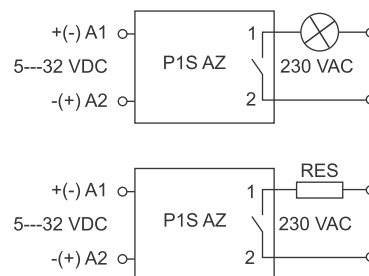
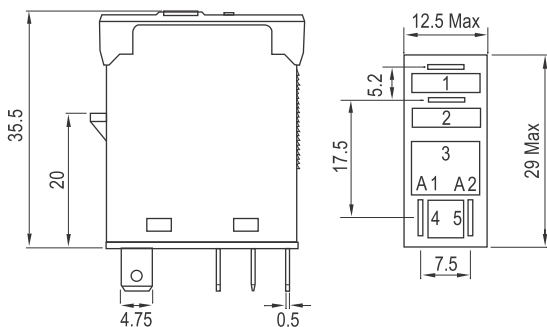

Approvals





P1S-DCN

Solid State Relay

**DC inductive or Resistive Load Switching.
Negative Common Output**

One open contact
2A @ 5 ... 50V DC



Input

Polarity protected

Range Of Input Voltage	5 ...32 VDC
Drop-out Voltage	< 2.5 VDC
Input Current	3 ± 1 mA
Current Stabilizer	Yes
Peak Inrush Voltage Protection	EC-1000-4-5 level 1

P1S-DCN

Common Negative

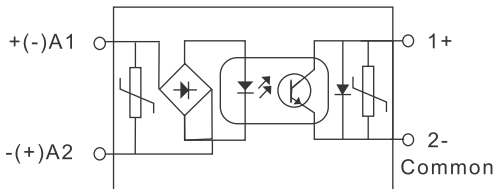

Out, Synchronized to Zero

Max. Output Current	2A
Max. Output Voltage	50 VDC
Minimum Output Voltage	5 VDC
Max.drop Output Voltage	1.3 VDC
Max. Leakage Current at 48 VDC	< 100 µA
Max. Over Current Pulse	5A, 350 µS
Pulse Protection	IEC-1000-4-5 level 1
Max. Current at Inverse Voltage	1 A

Max. DC load vs. Ambient Temperature

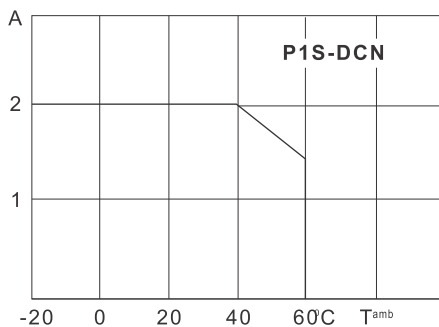

Specifications

DI-Electric Strength Input / Output	4 KV / 1min.
Operate Time	1 ms
Release Time	max.2ms
Working Temperature max.	60°C
Storage temperature	100°C
Weight	28 gr. Max.

Application

It is to switch upto 50V DC, Heating elements electro valves, motors, input / output signals on PLC's Solenoids incandescent and fluorescent lamps etc.

Inductive loads must be connected with a free wheeling diode in parallel.

Dimensions

in mm.

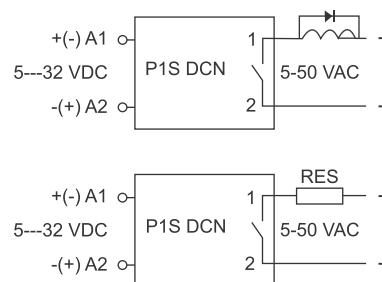
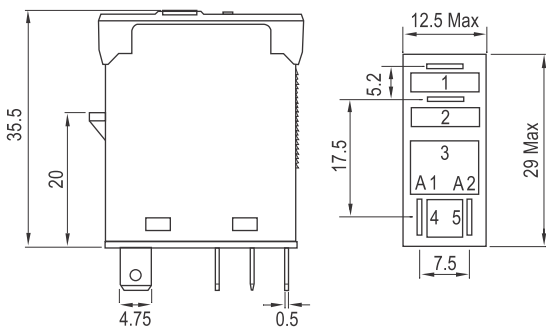

Approvals





P1S-DCP

Solid state realy

**DC Inductive of resistive Load Switching.
Positive Common Output**

One Open Contact
2A @ 5 50V DC



Input Polarity protec

Range Of Input Voltage	532 VDC
Drop-out Voltage	< 2.5 VDC
Input Current	5 ... 15 mA
Current Stabilizer	Yes
Peak inrush voltage Protection	EC-1000-4-5 level 1

P1S-DCP Common Positive

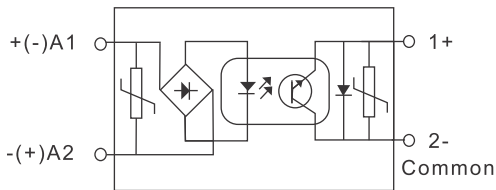

Output, Common Positive

Max. Output Current	2 A
Max. Output Voltage	50 VDC
Minimum Output Voltage	5 VDC
Max. Voltage Drop	1.3 VDC
Max. leakage current at 48 Vdc	< 100 µA
Max. Over Current Pulse	5 A, 360 µs
Pulse Protection	IEC-1000-4-5 level 1
Max. Current at Inverse Voltage	1 A

Max. DC load vs. Ambient Temperature

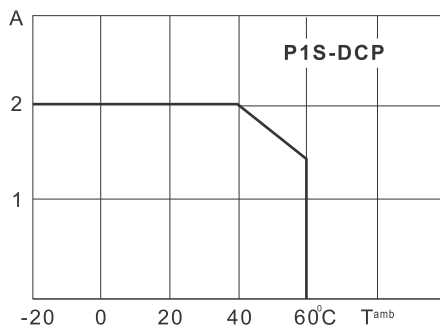

Specifications

Di-electric Strength Input / Output	4 Kv / 1min.
Operate Time	1ms
Release Time	max. 2ms
Working Temperature Max.	60°C
Storage Temperature	100°C
Weight	28 gr. Max.

Application

It is to switch upto 50V DC Heating Elements Electro Values, motors, input / output signals on PLC's, Solenoids Incandescent and Fluorescent Lamps etc.

Inductive load must be connected with a free wheeling diode in parallel.

Dimensions in mm.

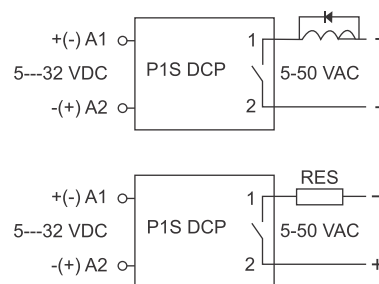
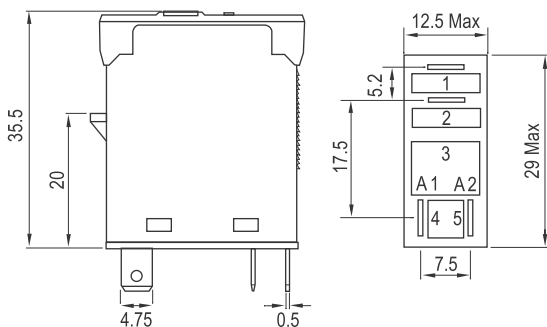

Approvals





P1S-DIP

Solid state reley for Input Application

**DC Resistive load
Common Positive Output**

One Open Contact
100mAmps @ 32VDC Max

P1S-DIP

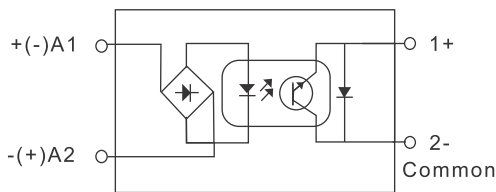

Dimensions

in mm.

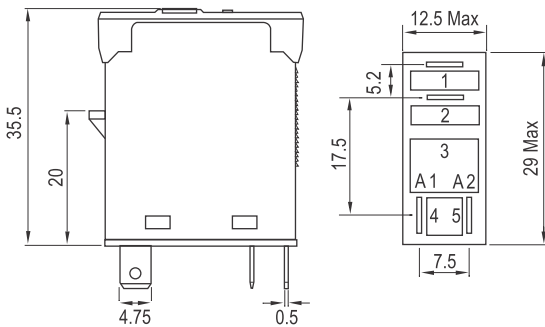

Input

Paramounts

Nomimal Input Voltage	Operating Voltage Range
5 VDC	4V - 6V
12 VDC	9.6V - 14.4V
24 VDC	19.2V - 28.8V
48 VDC	38.4V - 57.6V
110 VDC	88V - 132V
220 VDC	176V - 240V
115 VDC	92V - 138V
230 VDC	184V - 240V
100-240 VDC	90V - 250V

Input Current

5 / 12 / 24 / 48 / 110 / 220 VDC
115 / 230 / 100-240 VAC

4mA max

Output, Instantaneous

Max. Output Current 100mA DC
Max. Output Voltage 32VDC
Max. Voltage Drop 1.5VDC
Max. Leakage Current 100micro Amps
Maust Drop Out Vpltage 10% of Rated Voltage

Specifications

Isolation Between Input / Output 4 Kv / 1min.
Operate Time @ Rated Voltage 5 msecs Max.
Release Time @ Rated Voltage 5 msecs Max.
Working Temperature Max. 60°C
Storage Temperature -40° C.to +85°C
Weight 28gr. Max.

Application

for input. applications. for PLC controller.
for low current / low voltage DC signaling application

Standard Types

Dc : 5V, 12V, 24V, 48V, 110V, 220V. P1S - DIP input Voltage
AC 50 Hz.: 115V, 230V P1S - DIPVDC
AC 50 Hz.: 100V, 240V P1S - DIPVDC
P1S - DIPW P1S - DIPW

Approvals





P1S-DIN

Solid state reley for Input Application

DC Resistive load
Common Positive Output

One Open Contact
100mAmps @ 32VDC Max

Input Parameters

Nomimal Input Voltage	Operating Voltage Range
5 VDC	4V - 6V
12 VDC	9.6V - 14.4V
24 VDC	19.2V - 28.8V
48 VDC	38.4V - 57.6V
110 VDC	88V - 132V
220 VDC	176V - 240V
115 VDC	92V - 138V
230 VDC	184V - 240V
100-240 VDC	90V - 250V

Input Current
5 / 12 / 24 / 48 / 110 / 220 VDC
115 / 230 / 100-240 VAC } 4mA max

P1S-DIN

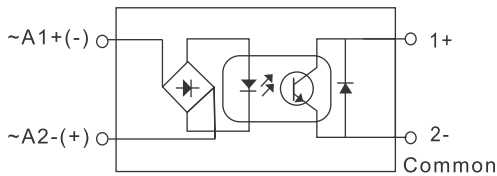

Dimensions

in mm.

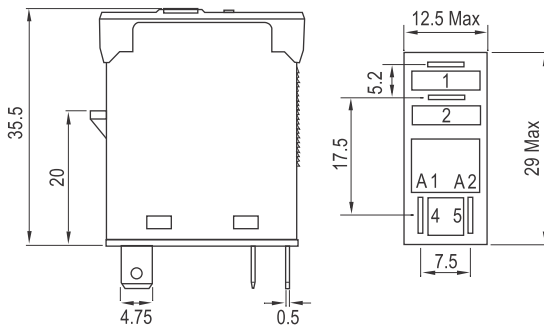

Output, Parameters

Max. Output Current 100mA DC
Max. Output Voltage 32VDC
Max. Leakage Current 100micro Amps
Maust Drop Out Vpltage 10% of Rated Voltage

Specifications

isolation between Input / Output 4 Kv / 1min.
Operate Time @ Rated Voltage 5 msecs Max.
Release Time @ Rated Voltage 5 msecs Max.
Working Temperature Max. 60° C
Storage temperature -40° C.to +85° C
Weight 28gr. Max.

Application

for input. applications. for PLC controller.
for low current / low voltage DC signaling application

Standard types

DC : 5V, 12V, 24V, 48V, 110V, 220V.	P1S - DIN input Voltage
AC 50 Hz.: 115V, 230V	P1S - DINVDC
AC 50 Hz.: 100V, 240V	P1S - DINVDC
	P1S - DINW

Approvals





S1D

Only
14 mm
WIDE

**Input / Output Socket [10A] for
P1 CO Relays DIN Rail or Panel Mountable**

Wiring Diagram



Specifications

Poles 1 Change Over Contact
Nominal load : 10A / 250V

Insulation: Di-electric strength, 1minute
Between contact and coil 5 KV
Between all terminals and DIN Rail 5 KV
Between adjacent terminals 3 KV

Brass Tin Plated Screw
Max. screw torque 1.2 Nm
Screw dimensions M3, Pozi

Wire in-lets capacity:
Solid Wire 4 mm² or 2 x 2.25 mm²
Multi core 22 14 AWG
Ferrule tip terminals 4 mm²

Dimensions in mm.

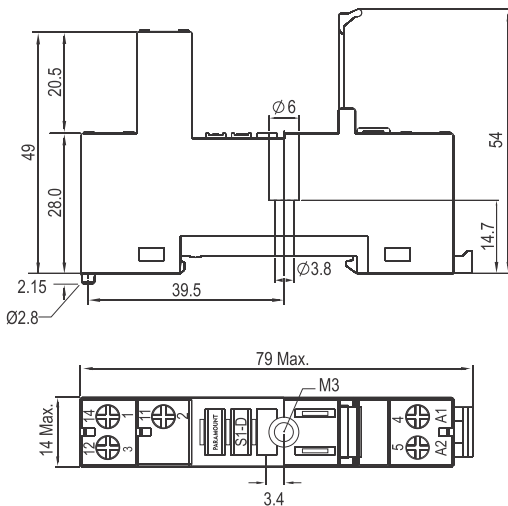

Other Aspects

Weight Approx. 28 gms
DIN Rail / Panel Mountable
Integrated Relay Hold Down Clip
Removable White Marking Label
EN / DIN Sequential Numbering according to EN 60947 & IEC 61810

Accessories



Accessories

Bridge Bar S1D-B1 & S1D-B4 for Coil Terminal (A2 / 5)

Dimensions in mm.



S1D-B1, 10A @ 250 VAC, 1 Way Bridge for Coil

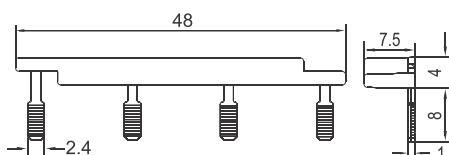

S1D-B4, 10A @ 250 VAC, 4 Way Bridge for Coil

Approvals





S10 K

Only
14mm
WIDE

**Input / Output Socket [10A] for
P1 Relays DIN Rail or Panel Mountable**

Wiring diagram

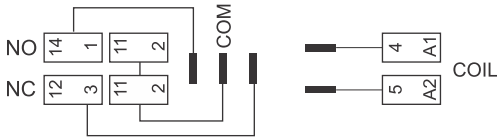

Dimensions in mm.

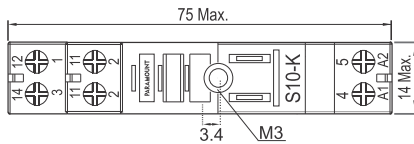
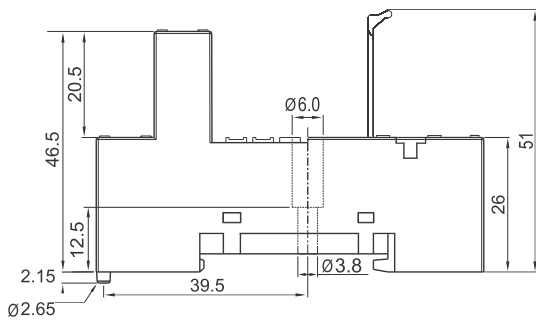

Specifications

Poles	1 Change Over Contact
Nominal load :	10A / 250V
Insulation: Di-electric strength, 1minute	
Between contact and coil	5 KV
Between all terminals and DIN Rail	5 KV
Between adjacent terminals	3 KV
Hard Brass Tin Plated Terminals	
Brass Tin Plated Screw	
Max. screw torque	1.2 Nm
Screw dimensions	M3, Pozi
Wire in-lets capacity:	
Solid Wire	4 mm ² or 2 x 2.25 mm ²
Multi core	22 14 AWG
Ferrule tip terminals	4 mm ²

Accessories



S10K-BB

S10K-B4

Other Aspects

Weight Approx.	28 gms.
DIN Rail / Panel Mountable	
Integrated Relay Hold Down Clip	
Removable White Marking Label	
EN / DIN Sequential Numbering according to EN 60947 & IEC 61810	

Dimensions in mm.

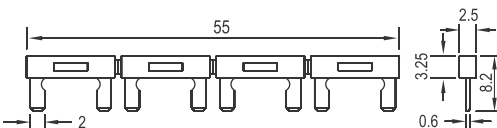

S10K-BB, 10A @ 250 VAC, 4 Way Bridge for Coil

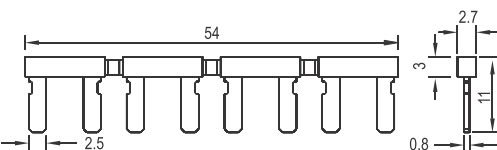

S10K-B1, 10A @ 250 VAC, 4 Way Bridge for Change Over

Note : In the S10K sockets the Change Over Contact Terminals (11/2) can be looped externally with S10K-B4 bridges.

Accessories

Bridge Bar S10K-BB for Coil Terminal (A2 / 5) &
Bridge Bar S10K-B1 for Change Over Terminal (11/2)

Approvals



S1-P

Printed Circuit Board Socket for P1 Relays



Specifications

Nominal load	10A / 250 V
Dielectric strength 1 min.	
Coil terminals to contacts	5 KV
Hard brass tin-plated terminals	0.3 x 1mm
Integrated Relay Hold Down Clip	
Weight Approx.	6 gms.

Dimensions

in mm.

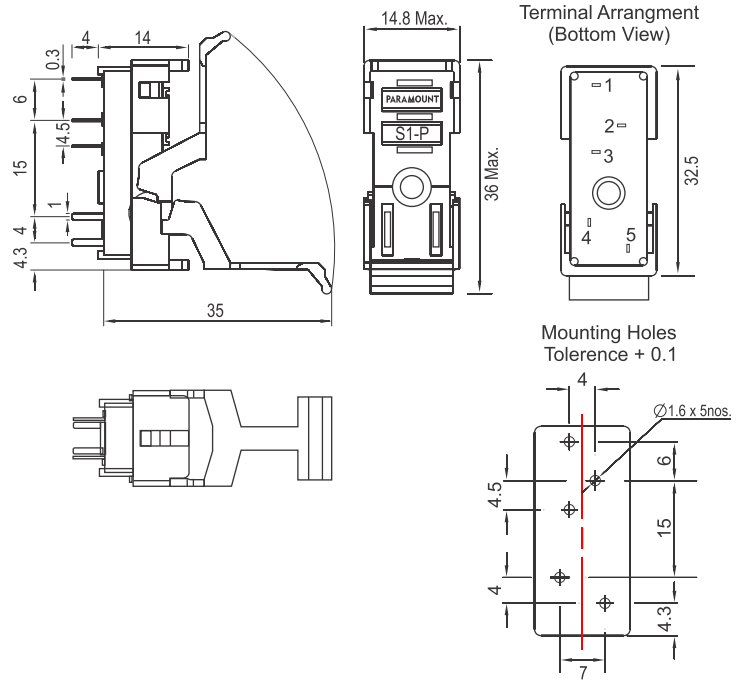

Approvals



S1D is the World's most compact (14mm width) DIN Rail Mountable Socket for the relays with the below Pitch & Pin configuration

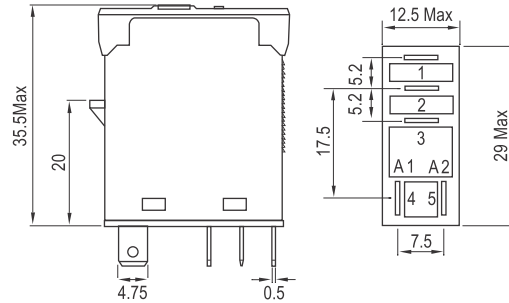

14mm width of the S1D DIN Rail Mountable Socket allows to mount 68 sockets on a Standard 35 mm Din Rail with a length of 1 meter / 1000 mm length (with a provision for 5 Nos of End stoppers each with a width of 8 mm)

Generally the PLC (Programmable Logic Controller) / DCS (Distributed Control System) output is 64 Bit output which requires 64 Relays to drive the load.

All the 64 Relays driven by a particular PLC / DCS can be mounted on a single 35 mm standard 1 Mt / 1000 mm Din Rail along with a provision to mount 4 Spare Relays.

The provision to mount 64 Relays on a single 35 mm Din Rail with 1 mt / 1000 length makes the wiring, identification of the relays from a particular PLC / DCS & maintenance very easy and convenient.

Mounting Tracks

All Dimensions in mm



PDR-15

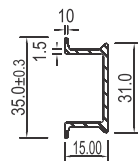
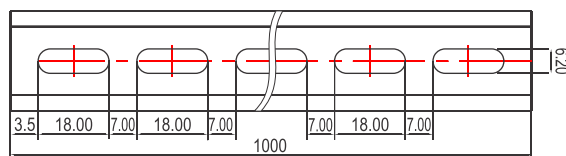

PDR-7.5

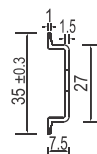
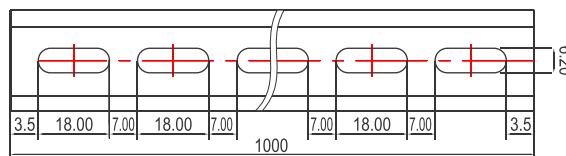

PARAMOUNT

EXPECT MORE...

Paramount Industries

#70, 5th Cross, SSI Area, Rajajinagar,
Bangalore - 560 010, India.

Tel : +91-80-22970010, 23157313, 23150828

Fax : +91-80-23302574, 28520623

Email : info@paramount.net.in

Website : www.paramount.net.in